

Groove Finishing Tools NUS of HSS-CO (Kob), HSS (Rap), TiN-coated and with Carbide Tips

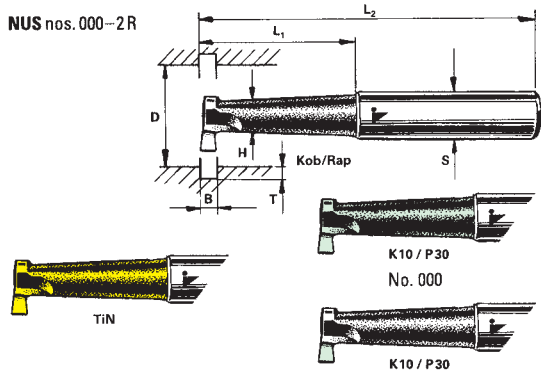

Heads: NUS nos. 3-10R
Shanks see page 12

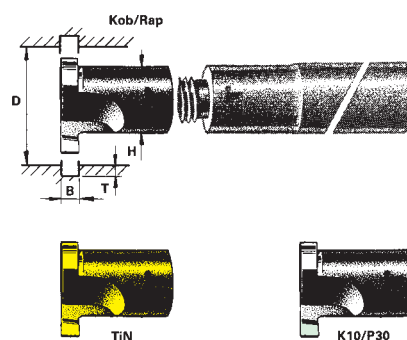

How to order (example): 5 pieces NUS-6-R-Kob. No. 00-2

Size NUS	Code number for righthand-side cutting (for lefthand-side cutting replace "R" by "L")	Availability								Recomm. minimum bore D / mm	Width B mm	Max. groove depth T mm	Ø of neck H mm	Ø S-h7 of shank mm	Thread	Length neck L ₁ mm	Total length L ₂ mm		
		"R"				"L"													
		Kob	Rap	TiN	K10	P30	Kob	Rap	TiN	K10	P30								
000	NUS-000-R...	●	●	●	●	●	○	○	○	○	○	5	1.2	1.3	2.6	8	—	15	46
00	NUS-00-R...	●	●	●	●	●	○	○	○	○	○	6.5	1.5	1.6	3.5	8	—	20	50
0	NUS-0-R...	●	●	●	●	●	○	○	○	○	○	9	1.8	2	4.8	8	—	26	52
1	NUS-1-R...	●	●	●	●	●	○	○	○	○	○	11	2	2.3	6	8	—	28	56
2	NUS-2-R...	●	●	●	●	●	○	○	○	○	○	13	2.2	2.9	7.5	8	—	—	64
3	NUS-3-R...	●	●	●	●	●	○	○	○	○	○	17	2.5	3.2	10	—	—	—	—
4	NUS-4-R...	●	●	●	●	●	○	○	○	○	○	21	3	3.5	12	M6 M8	—	—	—
5	NUS-5-R...	●	●	●	●	●	○	○	○	○	○	24	3.5	4.2	14	M10×20TPI	—	—	—
6	NUS-6-R...	●	●	●	●	●	○	○	○	○	○	28	4	4.7	16.3	M12×20TPI	—	—	—
8	NUS-8-R...	●	●	●	●	●	○	○	○	○	○	34	5	7	20	M15×20TPI	—	—	—
10	NUS-10-R...	●	●	●	●	●	○	○	○	○	○	42	6	8.5	25	M18×20TPI	—	—	—

▲ Please indicate here alloy or grade of carbide required

Grooving Tools HAS of HSS-CO (Kob), HSS (Rap), TiN-coated and with Carbide Tips

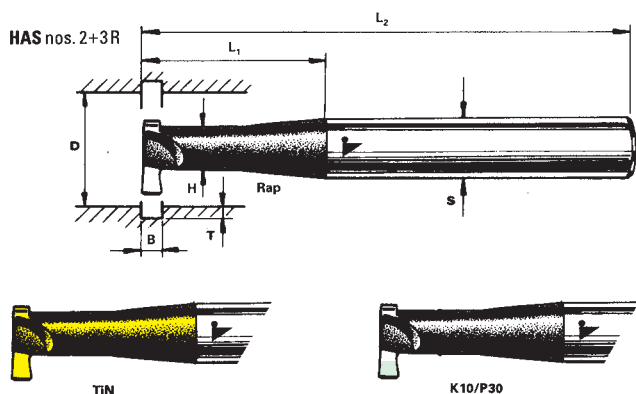

Heads: HAS nos. 4-10R
Shanks see page 12

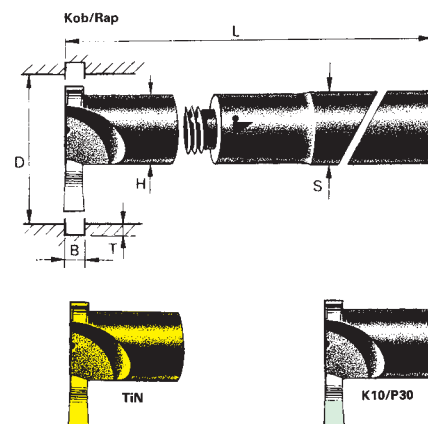

How to order (example): 5 pieces HAS-4-R-Rap.

Size HAS	Code number for righthand-side cutting (for lefthand-side cutting replace "R" by "L")	Availability								Recomm. minimum bore D / mm	Width B mm	Max. groove depth T mm	Ø of neck H mm	Ø S-h7 of shank mm	Thread	Length neck L ₁ mm	Total length L ₂ mm		
		"R"				"L"													
		Kob	Rap	TiN	K10	P30	Kob	Rap	TiN	K10	P30								
2	HAS-2-R...	●	●	●	●	●	○	○	○	○	○	17	3	4	8	10	—	29	80
3	HAS-3-R...	●	●	●	●	●	○	○	○	○	○	21	3.5	6	10	10	—	—	85
3 long	HAS-3-R-T...	●	●	●	●	●	○	○	○	○	○	21	3.5	6	10	12	—	40	150
4	HAS-4-R...	●	●	●	●	●	○	○	○	○	○	25	4	7	13	M8	—	—	—
6	HAS-6-R...	●	●	●	●	●	○	○	○	○	○	34	5	10	16.3	M12×20TPI	—	—	—
8	HAS-8-R...	●	●	●	●	●	○	○	○	○	○	40	6.5	11.5	20	M15×20TPI	—	—	—
10	HAS-10-R...	●	●	●	●	●	○	○	○	○	○	48	8	13	25	M18×20TPI	—	—	—

▲ Please indicate here alloy or grade of carbide required

Availability: ● ex stock / ○ within short notice